

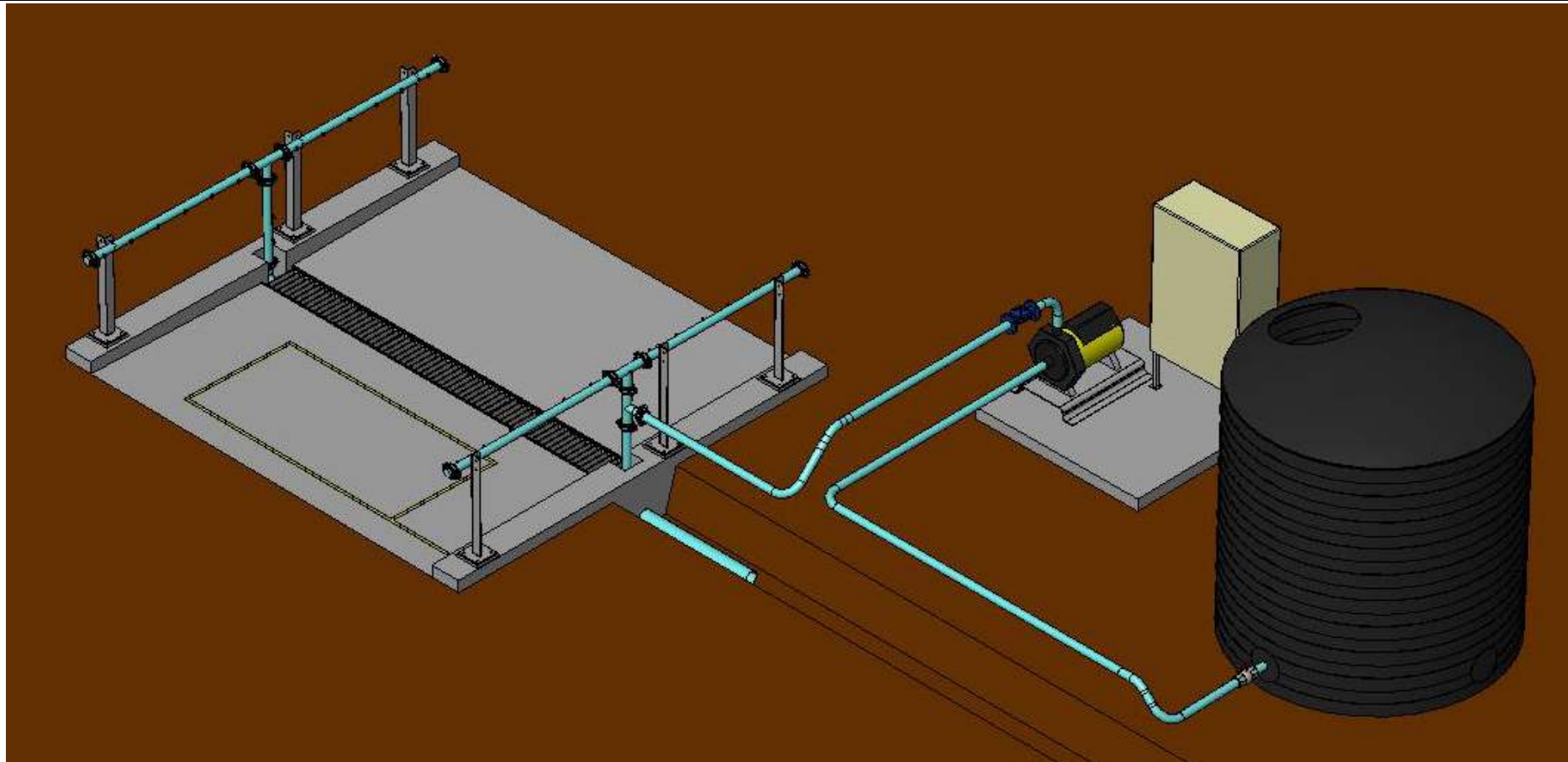

LAYOUT DWG – DU2CB



Display layout only. Actual installation layout may vary to suit site requirements.

Specifications		DU2CB			
Footprint	3.5m x 3.8m	Spray Jets	36	MCC	IP66
Max. Vehicle Width	2.5m	Automatic Start	Yes	Power Requirements	
Max. Axle Loading	8 Tonnes	Traffic Management Systems	Optional	Pump Size	1.1kw
Trench Width	300mm	Chemical Dosing Equipment	Yes		240v
Wash Boom Config.	2 x 3m	Chemical Pre-Mix Tank	6kl	Power Loading	15amps

No.	Revision Info	By	Date	For Information Only "Not For Construction"	Fleetwash Industrial Systems Pty Ltd Range: Cyclone Product: Decontamination Unit Model No.: DU3CB ©2009 Fleetwash Industrial Svstems Ptv Ltd	
	24/3/09 ©2009-Fleetwash Industrial Systems Pty Ltd	PW	24/3/09	Scale: Not To Scale		